



*B-270 Manual Hand Wheel Operated*



**V-TORK®**  
WORLD CLASS INDUSTRIAL VALVES

# B-270

## BI-DIRECTIONAL KNIFE EDGE GATE VALVE

The **V-TORK® B-270** Bi Directional Lug Type Knife Gate Valve is designed to handle pressure or flow from either directions, mainly for ON-OFF applications in abrasive and corrosive slurry lines of various industries. It features a single piece cast body with heavy duty stainless steel gate & Replaceable U-Shaped Metal wire impregnated Elastomer Seal which provides a peripheral seal along the edge of the gate that gives 100% leak-proof and greater reliability. In the open position the valve offers maximum flow area and minimum resistance to flow (and lowest pressure drop) and in the closed position there is no raised seat in the flow path.

### DESIGN / MANUFACTURING / TESTING STANDARD



### SIZE RANGE

2" to 64" (50MM to 1600MM)

### PRESSURE RATING

150 CWP (1030 kPa)

### SEATING

Soft Seated (Replaceable U shaped Metal Wire Impregnated Elastomer Seal)

### OPERATION

Lever, Hand Wheel, Chain Wheel, Bevel Gear, Hydraulic Cylinder, Pneumatic Cylinder, Electrical Actuator etc.

### ACCESSORIES

Limit Switch, Solenoid Valve, Positioner Air Filter Regulator etc.

### APPLICATIONS

**Waste Water Treatment** (Digester Isolation, Sludge discharge, Sewage),  
**Cement Plants** (Slurry transfer, Dry Lime, Pneumatic conveying systems),  
**Paper & Pulp** (Pulp preparation, Pulp Transfer, stock tower isolation), **Sugar Plants**,  
**Minerals & Metals** (Pneumatic conveying systems, iron ore slurry, Beneficiation plant, Blast Furnace),  
**Chemical & General Industries** (Dry Solids bagging, Hopper Dump, Pump isolation & silos)

## SEATING ARRANGEMENT

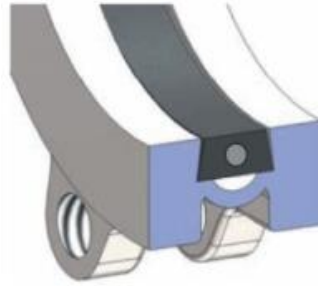
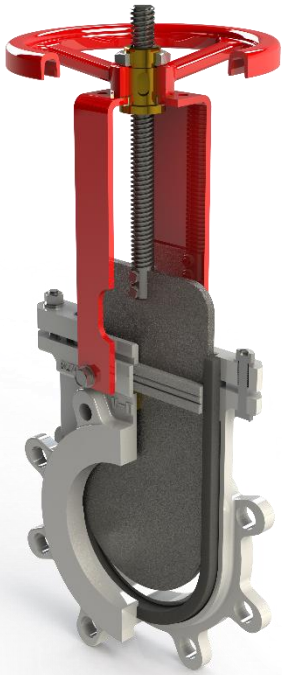

DN 50 to DN 500 – Single Piece Body with Extruded Rubber Seal

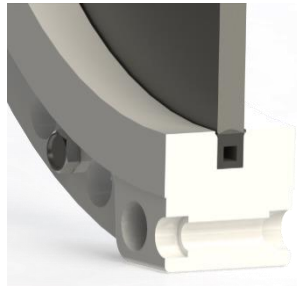

DN 600 and above – Split Piece Body with Extruded Rubber Seal

The Seat is retained in the valve Body's internal groove by its trapezoidal shape and is in contact with the gate around its perimeter. This design provides water tightness and seamless liquid flow in both directions while avoiding any buildup of solids that could prevent the valve from closing.

## MATERIAL OF CONSTRUCTION

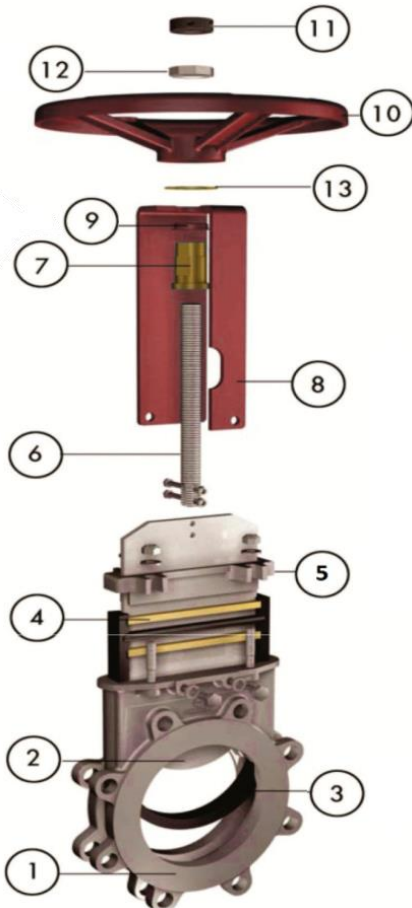

SL No	Part Name	Material								
		Ductile Iron	Cast Iron	Cast Steel	CF8	CF8M	CF3M	CG8M	CG3M	CK3MCuN
1	Body	ASTM A 536	IS 210	ASTM A 216	ASTM A 351	ASTM A 351	ASTM A 351	ASTM A 351	ASTM A 351	ASTM A 351 Gr. CK3MCuN
		Gr. 60-40-18	FIG 200	Gr. WCB	Gr. CF8	Gr. CF8M	Gr. CF3M	Gr. CG8M	Gr. CG3M	
2	Gland	ASTM A 536	IS 210	ASTM A 216	ASTM A 351	ASTM A 351	ASTM A 351	ASTM A 351	ASTM A 351	ASTM A 351 Gr. CK3MCuN
		Gr. 60-40-18	FIG 200	Gr. WCB	Gr. CF8	Gr. CF8M	Gr. CF3M	Gr. CG8M	Gr. CG3M	
3	Gate	ASTM A240 Gr. SS 304			ASTM A240 Gr. SS 316	ASTM A240 Gr. SS 316L	ASTM A240 Gr. SS 117	ASTM A240 Gr. SS 117L	ASTM S31254 SMO 254	
4	Seat	Nitrile / EPDM / Viton®								
5	Stem	SS410			ASTM A182 Gr. F316				Gr. F44	
6	Stem Nut	2"-6" Brass		8" & Above SS410		ASTM A182 Gr. F316		ASTM A182 Gr. F44		
7	Gland Packing	PTFE Impregnate Synthetic Fiber (Optional-Graphite / Ceramic), O Wire EPDM (Optional Viton®)								
8	Support Plate	ASTM A36 Gr. Carbon Steel / SS304								
9	Hand Wheel	S.G IRON / Fabricated								
10	Gate Cover	MS / SS304 Sheet								
11	Stem Protector	MS Pipe – Powder Coated								
12	Thrust Washer	PTFE								
13	Thrust Washer	Brass								
-	Fasteners	Steel / SS304 / ASTM A193-B8 / A193-B								

## DIMENSIONAL DETAILS

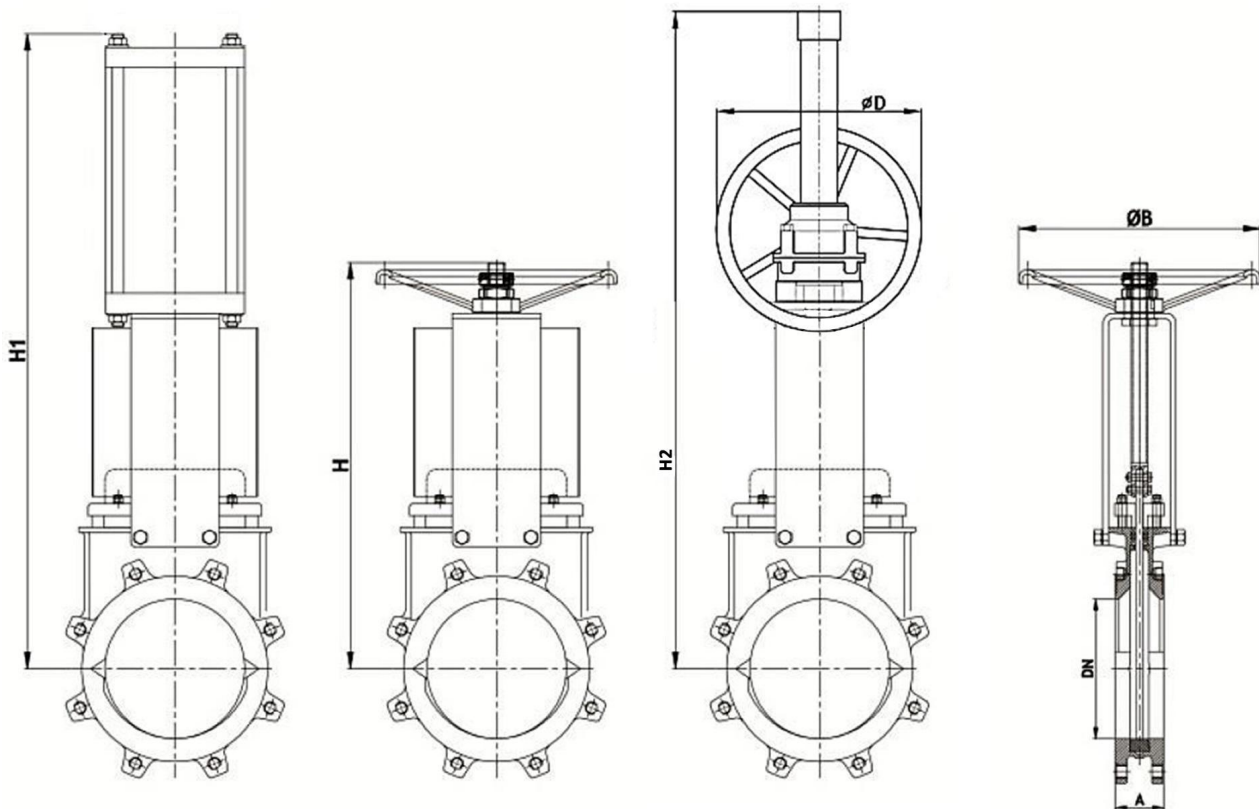

Size	A	ØB	ØD	H	H1	H2
In mm	In mm	In mm	In mm	In mm	In mm	In mm
50	48	210	200	420	420	540
80	51	210	200	480	505	575
100	51	310	200	560	570	620
150	57	310	200	680	720	730
200	70	310	200	850	880	970
250	70	350	200	1080	1050	1140
300	76	350	200	1195	1190	1210
350	76		300		1380	1520
400	89		300		1510	1580
450	89		400		1690	1840
500	114		400		1840	1950
600	114		400			2190
700	117		400			2490
800	140		400			2910
900	140		500			3280
1000	145		500			3620
1200	150		600			4280
1400	160		600			5020
1500	170		600			5530
1600	170		600			5910

**DISCLAIMER:** V-TORK® cannot accept responsibility for possible errors in catalogues, brochures, other printed materials, and website information. V-TORK® reserved right to alter its products without notice including products already on order provided that such alteration can be made without changes being necessary in specifications already agreed. The V-TORK® & V-TORK® Logo types are registered trademarks of V-TORK CONTROLS®.



Address : 187/2A SNMV College Road, Malumichampatti, Coimbatore 641050,  
 Tamilnadu, INDIA  
 Phone: +91 7598718922 Email: sales@vtorkcontrols.com, vtorkcontrols@gmail.com  
 Website: www.vtorkcontrols.com



**V-TORK®**  
 WORLD CLASS INDUSTRIAL VALVES